

# Break-Away Lift Insert

Injection molded  
ABS Plastic

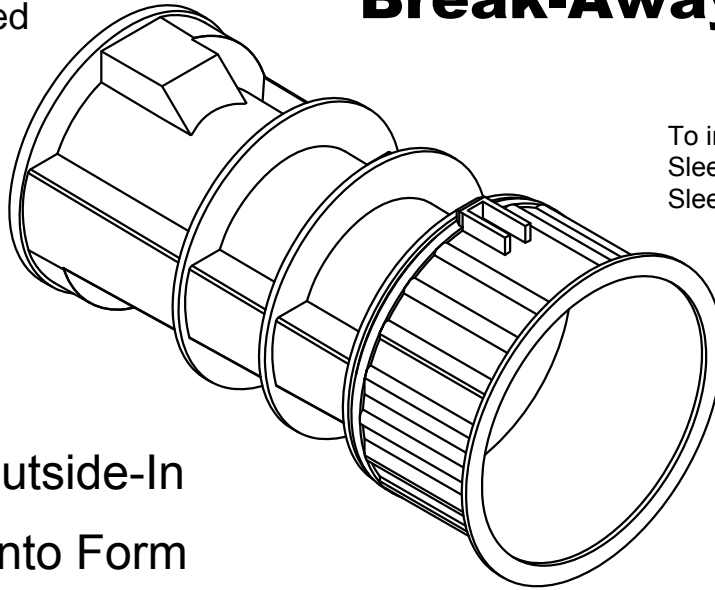

To install use with 004-747 Steel Sleeve that locates insert onto form. Sleeve is welded to jacket of form.

Installs from Outside-In  
No Reaching Into Form

Breaks Away  
from lift Insert  
during stripping

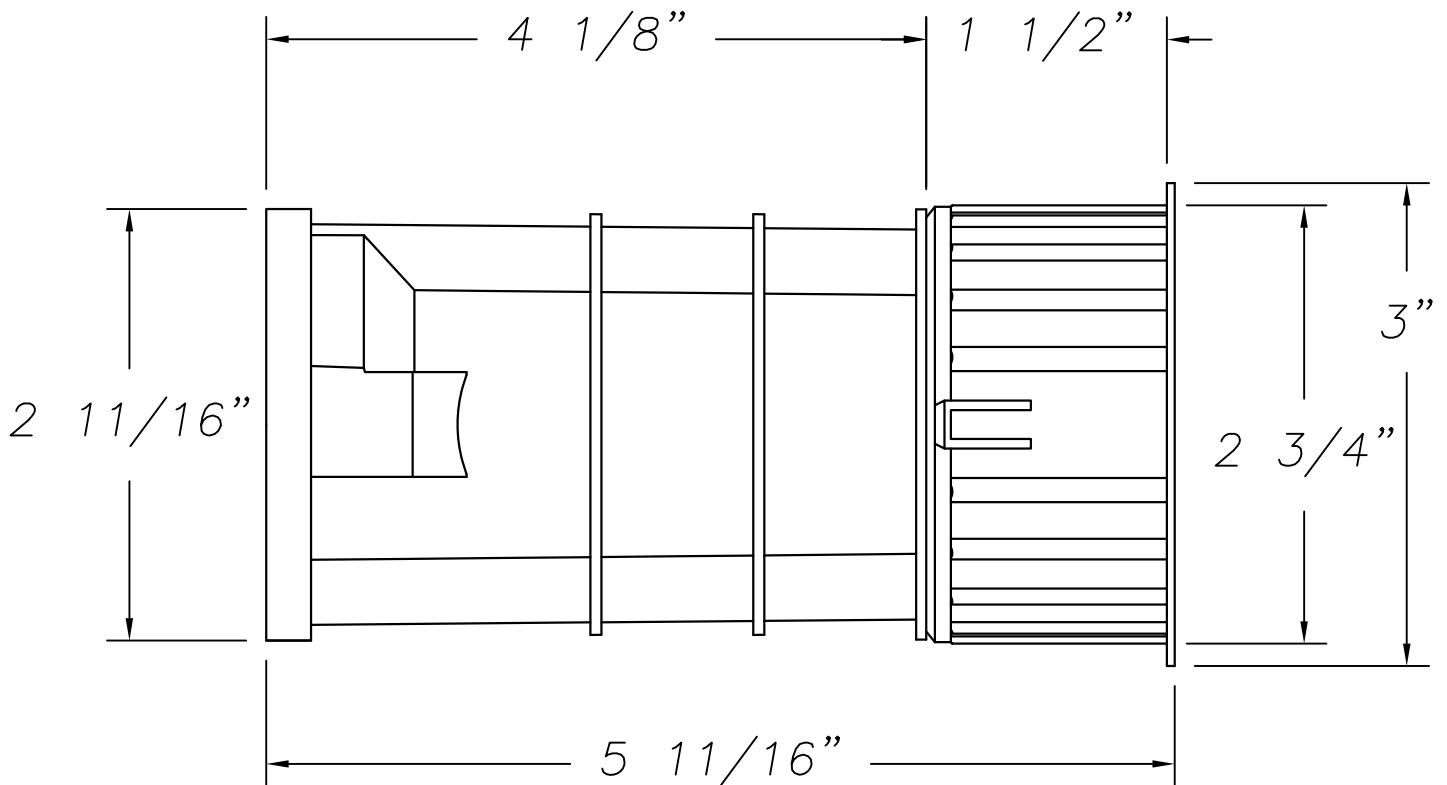

**3500 lbs Safe Working Load - 4:1 Safety Factor**

Meets OSHA 1926.704c requirements

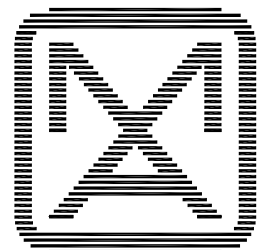

**M . A . I N D U S T R I E S , I N C .**